

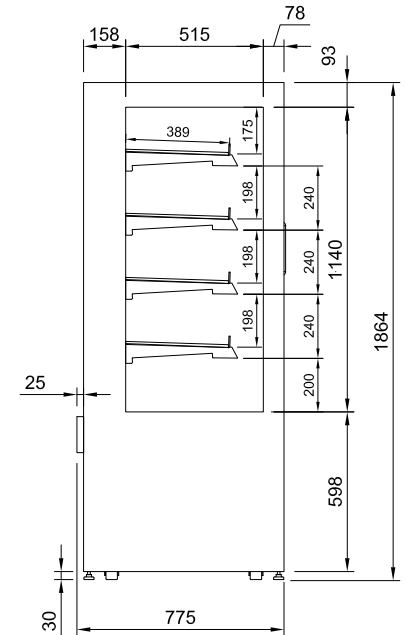

## HT DTGHT6 DTGHT9

- Stainless steel construction
- Four Stainless steel heated shelves
- Ticket strips on shelves
- Shelf mounted air curtains
- Forced air circulation
- Under shelf and canopy LED lights
- Frame less hinged glass front doors
- Opening front grille panel
- Roll in on castors with adjustable feet
- ECO mode turns of heat on two bottom shelves and base

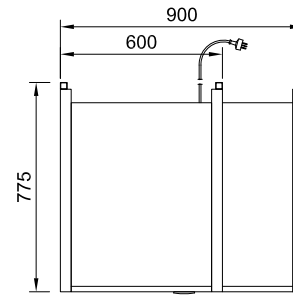

### TICKET STRIP

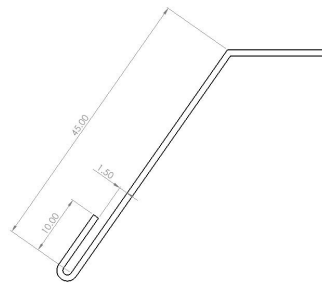

## CABINET DIMENSIONS & SPECIFICATIONS

MODEL	CABINET				SHELVING	OPERATING TEMP	SHELF	BASE TRAY	DISPLAY	FREQUENCY	OPERATING CURRENT	POWER	CONNECTION		VOLTAGE			PACKED FOR SHIPPING		
	LENGTH [MM]	DEPTH [MM]	HEIGHT [MM]	WEIGHT [KG]									ELECTRICAL POWER CORD 2200MM		Volts	LENGTH [MM]	DEPTH [MM]	HEIGHT [MM]	WEIGHT [KG]	
DTGHT6	600	775	1860	139	4 + BASE	70 -85	486 X 387	520 X 533	0.98	50/60 HZ	7.2	1.9	10 AMP 3 PIN PLUG		220-240V	700	830	2030	175	
DTGHT9	900	775	1860	178	4 + BASE	70 -85	786 X 387	820 X 533	1.63	50/60 HZ	10.5	2.33	15 AMP 3 PIN PLUG		220-240V	1000	830	2030	215	

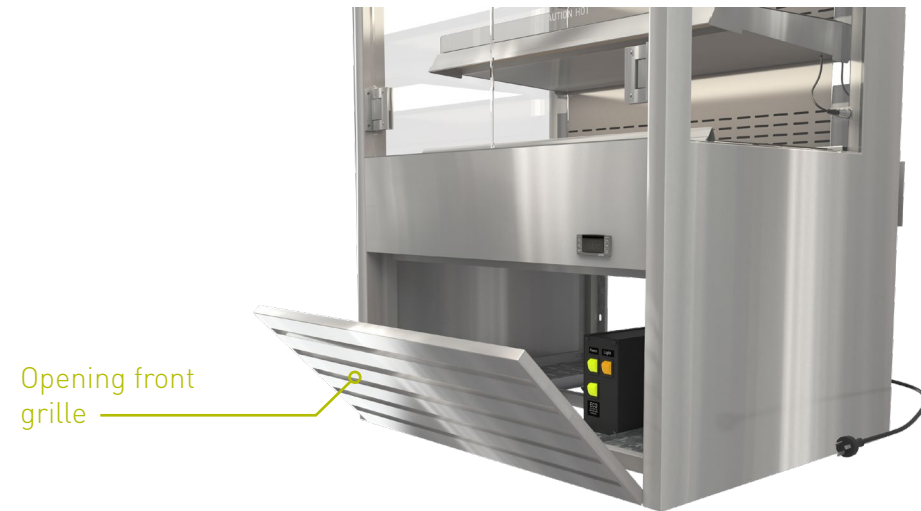
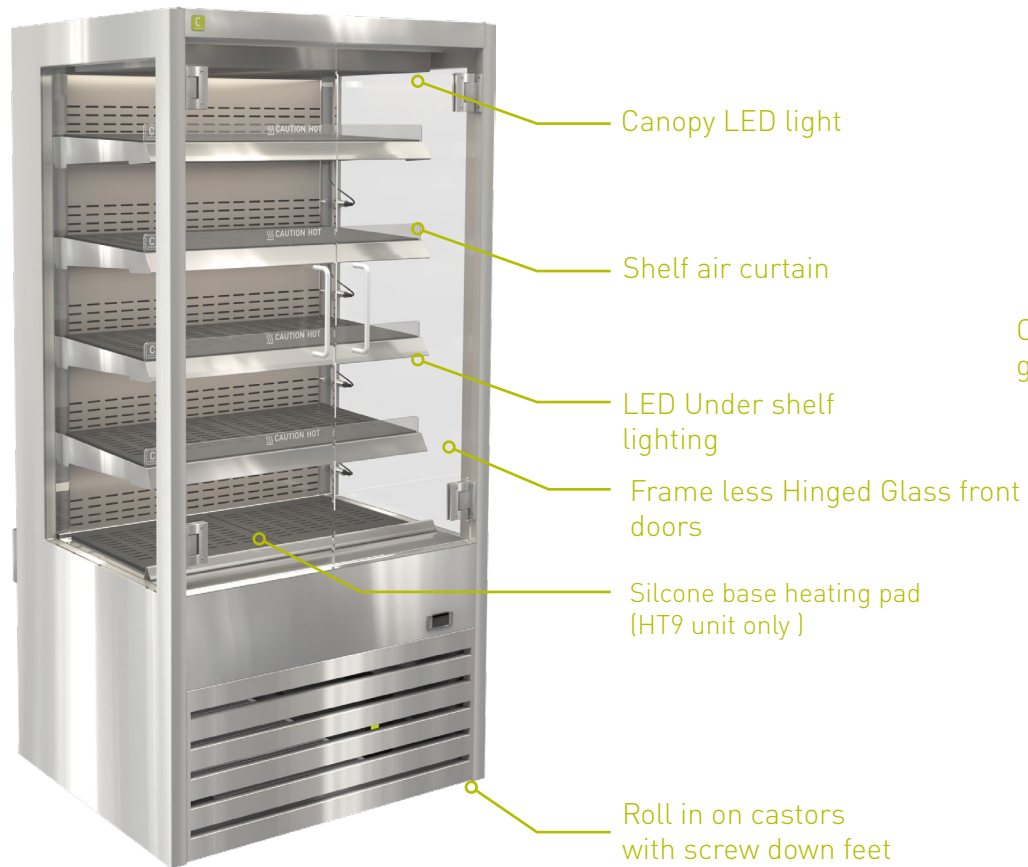

**POWER SWITCH**  
All fans and heating elements on (with ECO switch off) standard operating state.



**LED LIGHT SWITCH**  
All LED lights on. If optional light box is fitted the light box will power on with power switch.

**ECO SWITCH** - power switch must be on.

**ECO ON** - two lower shelves , fans and silicone base heating pad (HT9 unit only) - ARE OFF

**ECO OFF** - all shelves , fans and silicone base heating pad (HT9 unit only) - ARE ON



- Top mounting bracket
- 8mm Glass front light box with L.E.D. white back lit panel
- Custom PVC graphic slides into light box

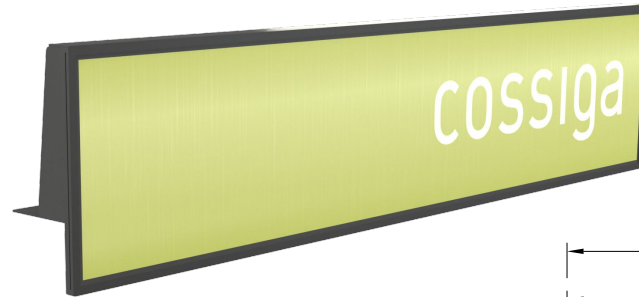

Custom graphic panel inserted into frame ( see sizes in table )

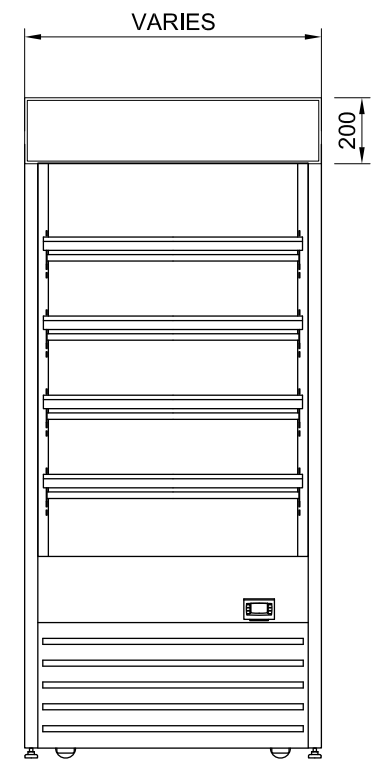
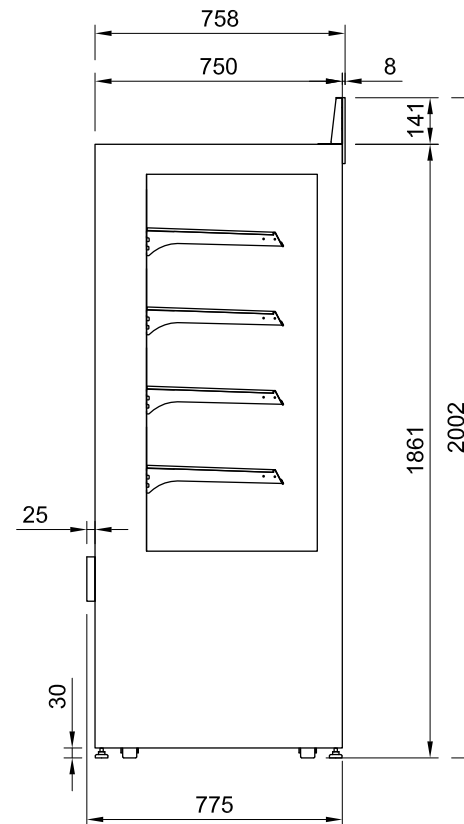
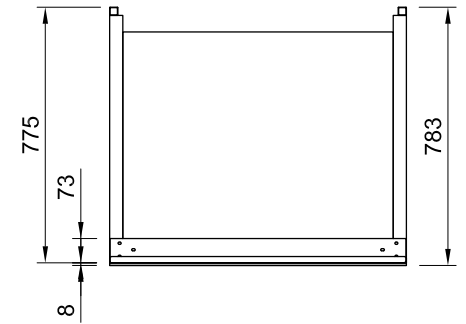

## LIGHT BOX SIZES

See Light box assembly document

MODEL	OVER ALL LENGTH	HEIGHT MM	GRAPHIC PANEL SIZE W X H
DTG6	600	200	595 X 189
DTG9	900	200	895 X 189

Fitted to top of unit with supplied brackets



- Top mounting bracket
- Digital display screen
- High Gloss picture
- Data input from USB

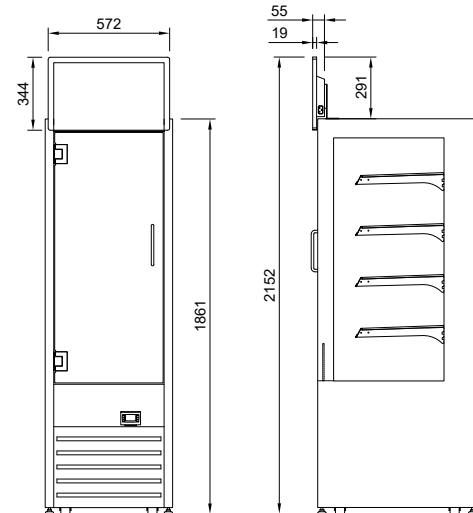
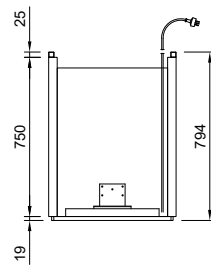

**DIGITAL SCREEN**  
sold as accessory kit

- Steel rack black coated
- Clips onto front grille

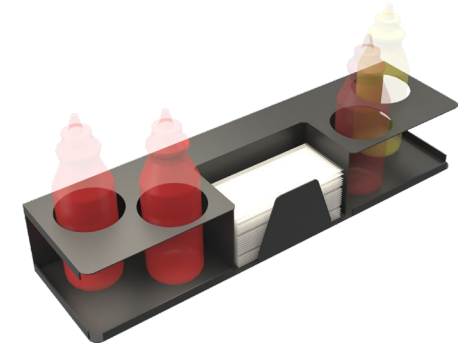

**SAUCE RACK** AVAILABLE UK / EUR ONLY  
sold as accessory kit

## Separation between cold and heated units

Cold and heated units must be separated with a minimum gap of 150mm to avoid heat transfer between cabinets

DTG OR REFRIGERATED

DTG HT HEATED



150mm minimum gap between cold and hot units

No Minimum gap required between cold units together

No Minimum gap required between hot units together

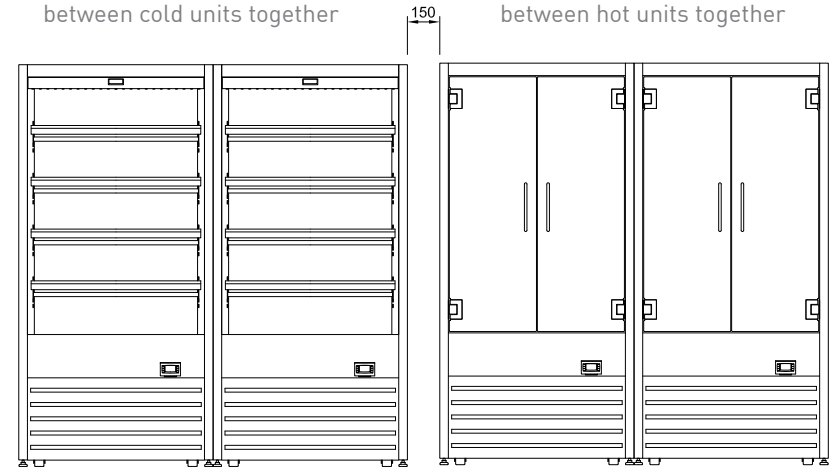

DTG OR REFRIGERATED

DTG HT HEATED



## Full Wrap

front and side facing  
areas covered  
(excludes top and rear)



## Front Wrap

Only front facing  
areas covered



- Stainless steel buffer
- Screw fixed to unit frame

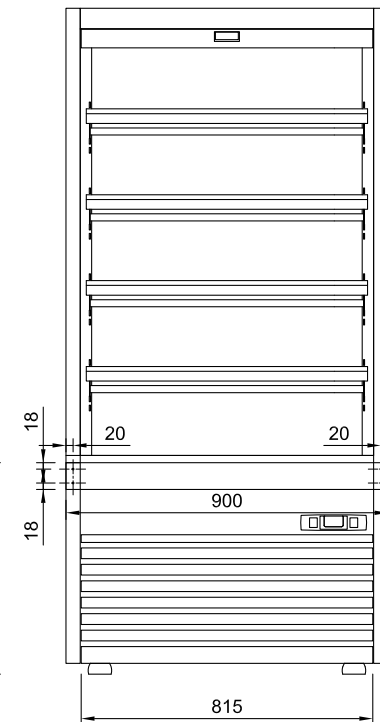
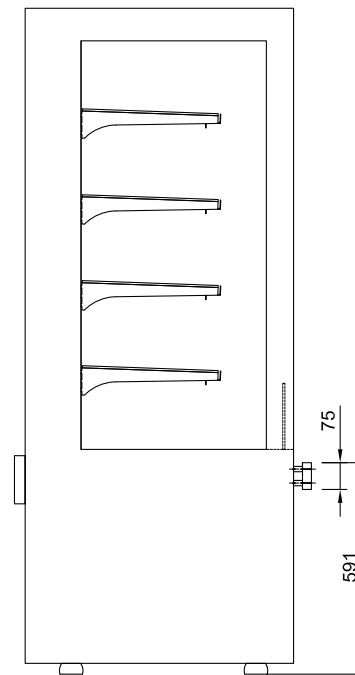
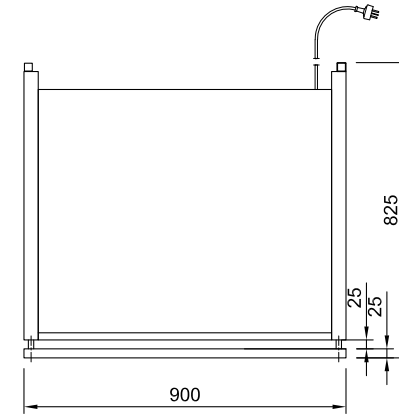

self tapping screws with spacers

## BUFFER STRIP BAR

MODEL	BUMPER STRIP SIZES		
	OVER ALL BUFFER LENGTH	HEIGHT MM	SCREW FIXING POINTS
DTG6	600	75	2
DTG9	900	75	2



1. Lift off truck on pallet with the **rear of the unit facing the forklift**



2. Unpack. Remove front grill.

Tools Required



3. Lift with forks under centre of frame. **Check span of forks under unit to avoid any damage to components.**



4. Transport to required location



## Tools Required



1. Lift of transport on pallet with the **rear of the unit facing the forklift**

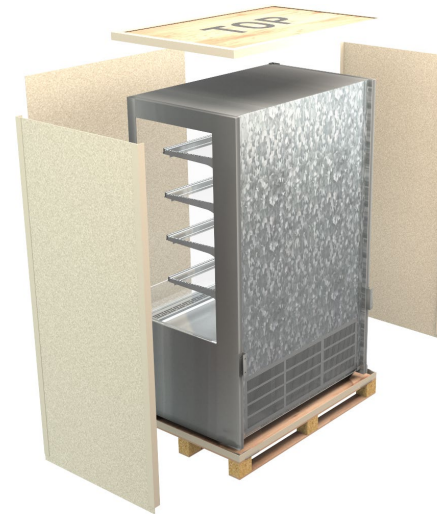

2. Place the boxed unit on a level floor area. Remove plywood top cover and put aside. Remove front, side and corner pieces and discard.



3. Locate the four metal brackets in the accessory pack.



4. Place three or four of the metal brackets on a level floor in front of the bottom pallet with the **rear of the cabinet facing the ramp**. Place the plywood top cover on the floor and corner brackets to form a ramp.



5. Carefully roll the unit off the pallet down the ramp. Two or more people may be required depending on the size of the unit.