

cossiga logo is on the left front of gantry

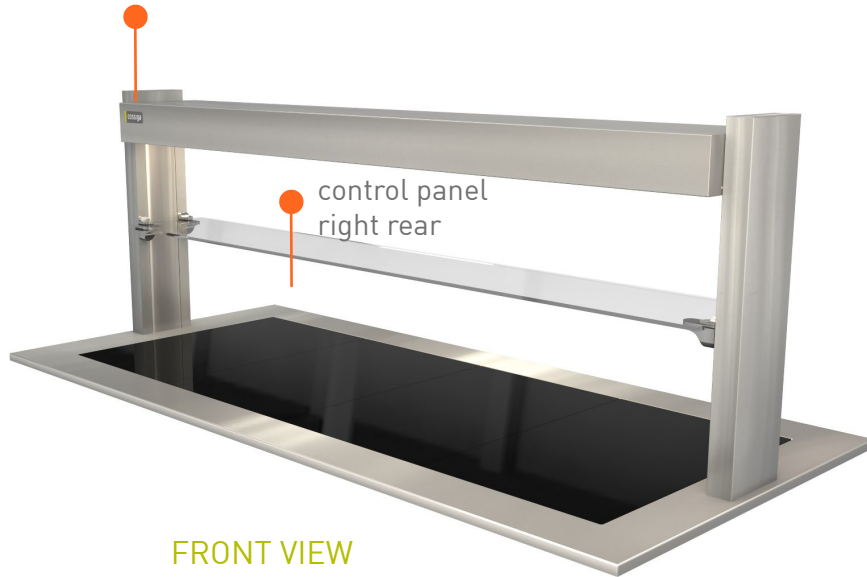

FRONT VIEW

LS CM GANTRY ASSEMBLED

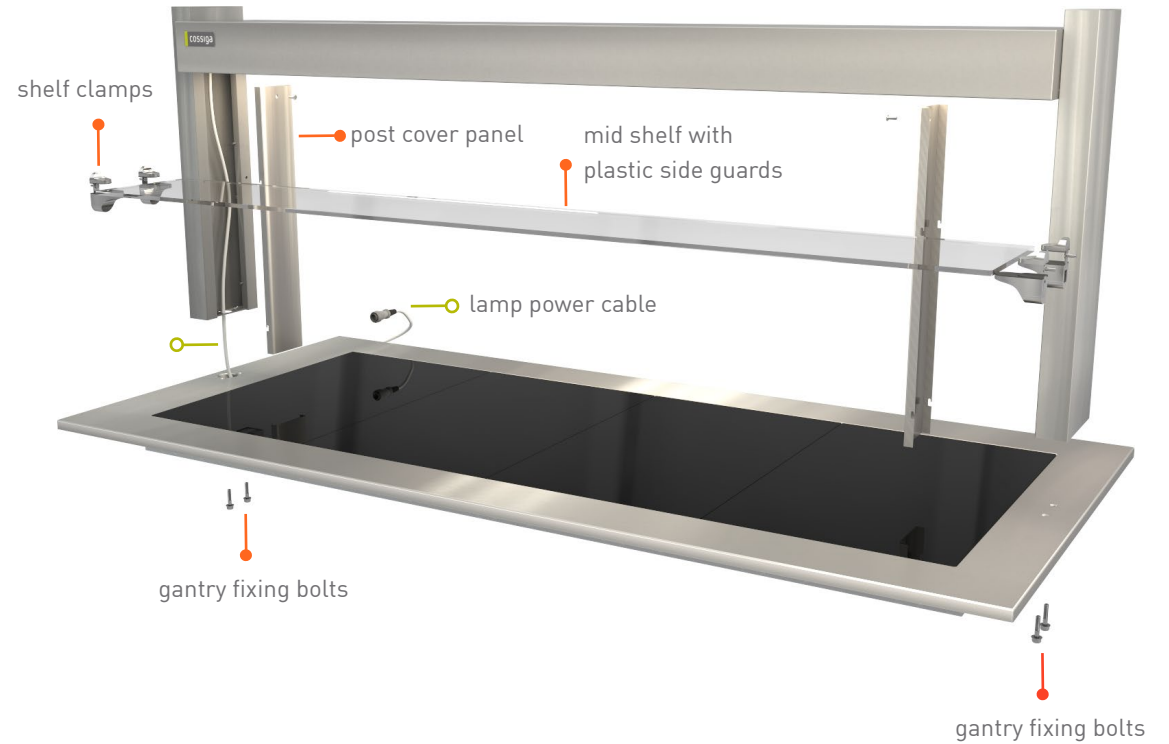

EXPLODED GANTRY DIAGRAM

- Do not overtighten bolts and screw fixings
- If gantry is NOT used go to step 10 - blanking plates

PLACING LS UNITS IN COUNTER

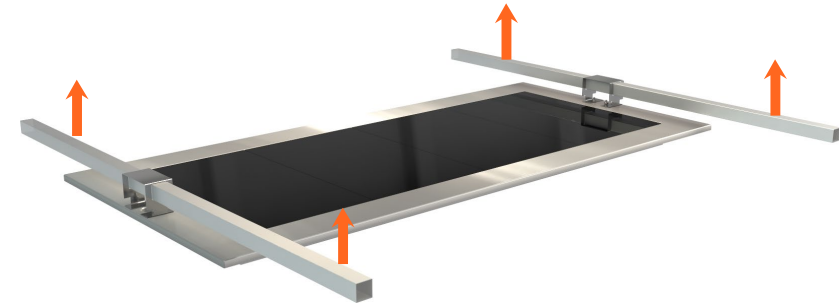
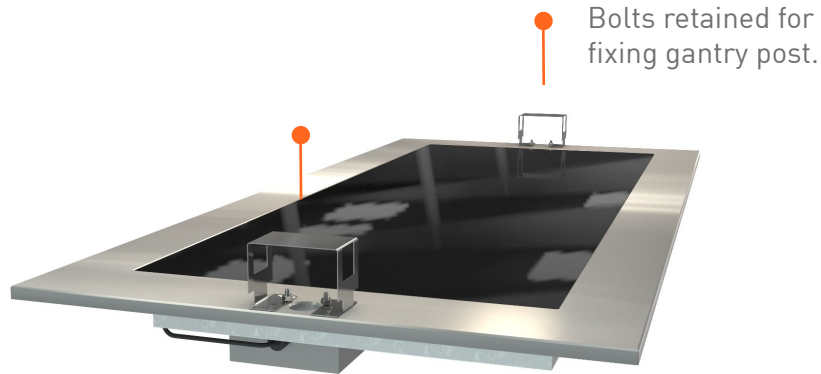

Use four people lifting each corner.

- 1 Lifting brackets are fitted to assist removing the unit from the packaging and placing in cabinetry. Use a lift bar that can fit through the 35 x 35mm square hole. (not supplied)



2. After unit has been placed in the required position remove the lifting bracket bolts and retain for fixing the gantry posts.

All accepted local safety work wear and standards should be adhered to with a safety programme developed before undertaking of this kind of lifting work.

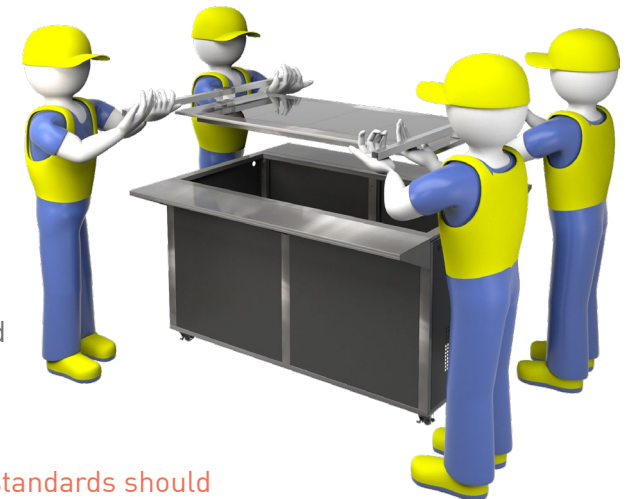

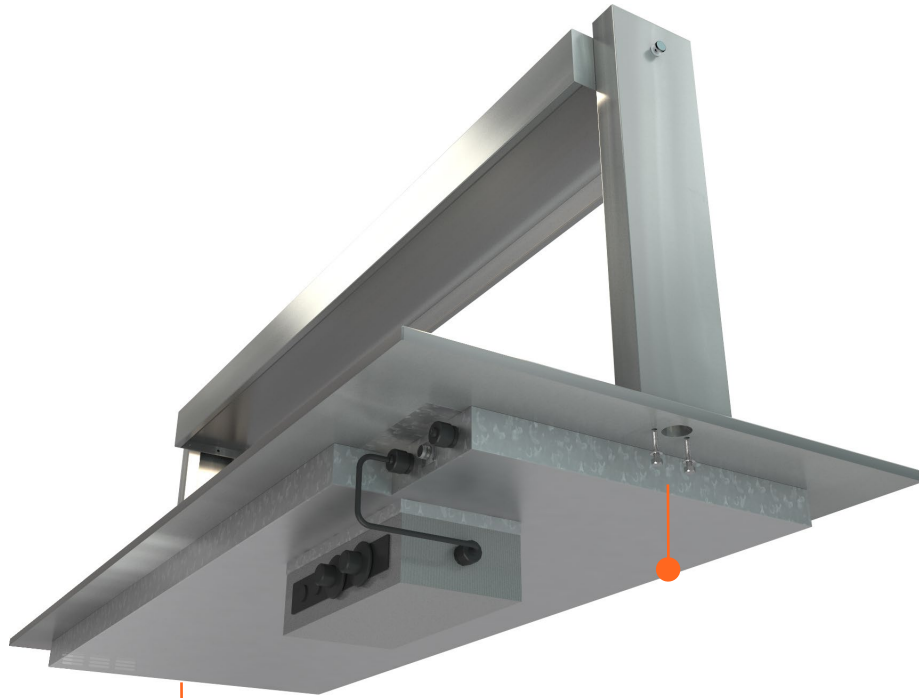

The control panel is on the right hand side when looking from the rear of the unit.

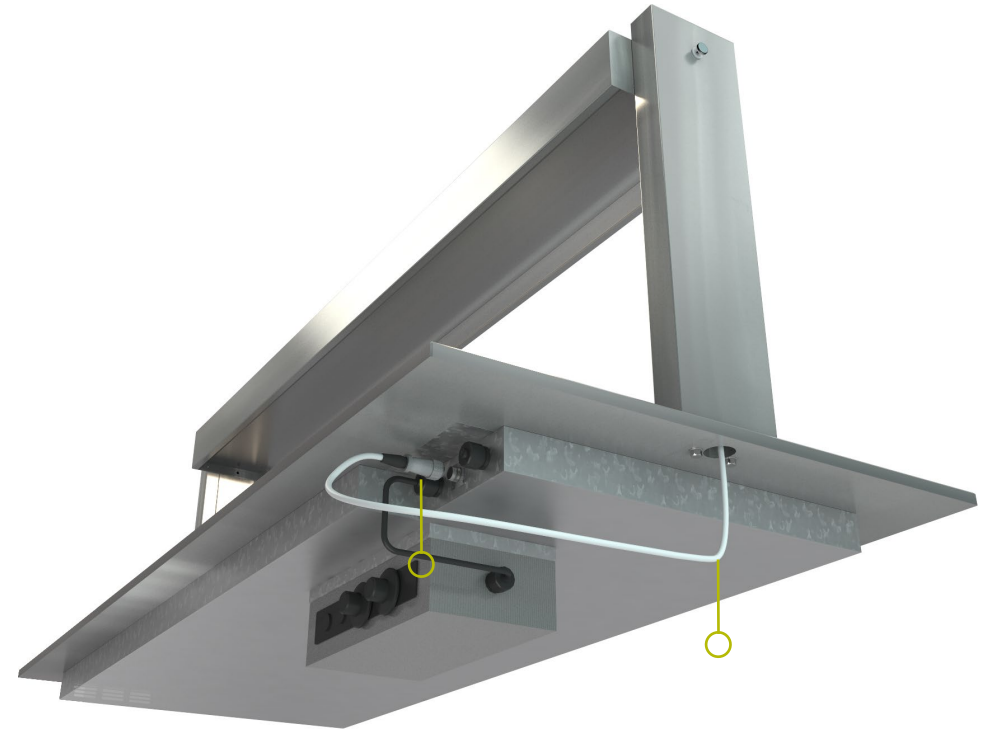

3.

Remove side post covers lift up and out from bottom. Position gantry assembly over CM base screw up fixing bolts with washers from underneath on both sides.

4.

Feed the lamp power cable through the base hole and plug into socket and screw up.

The cossiga logo is on the left front side of the gantry.

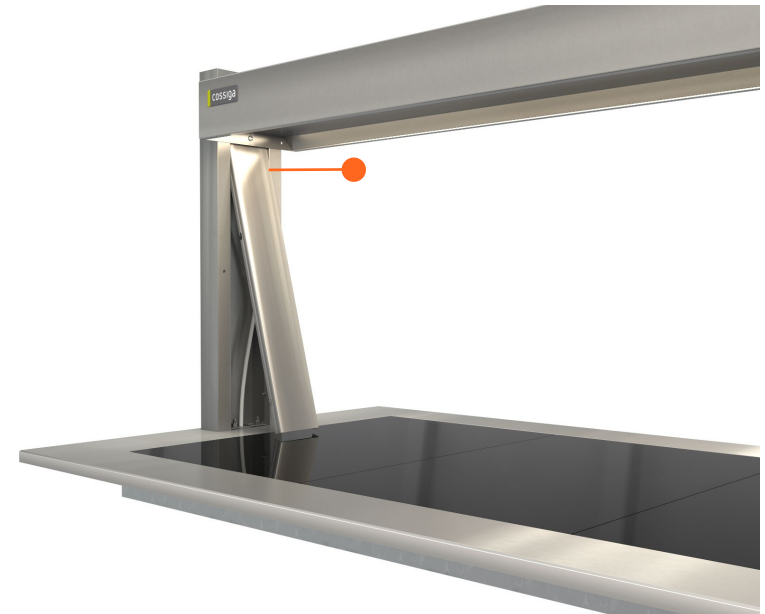

5.

View of gantry and lamp cable on left side of unit from the front.

6.

On each side post slide up the post cover panel. position into clips and pull down to fit.

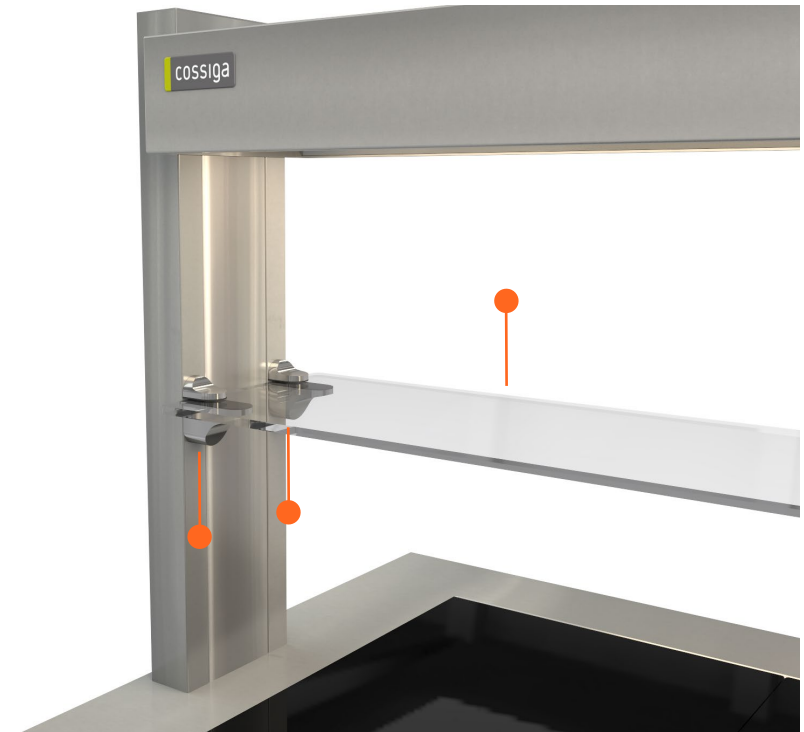

7.

- For each of the 4 shelf clamps -
- 1. Release bottom screw to open clamp.
- 2. Screw in clamp to post holes.

8.

- Insert glass shelf and centre. Tighten shelf clamps using underneath screw to suit. Plastic guards remain on the glass to prevent glass chipping into food product if knocked.

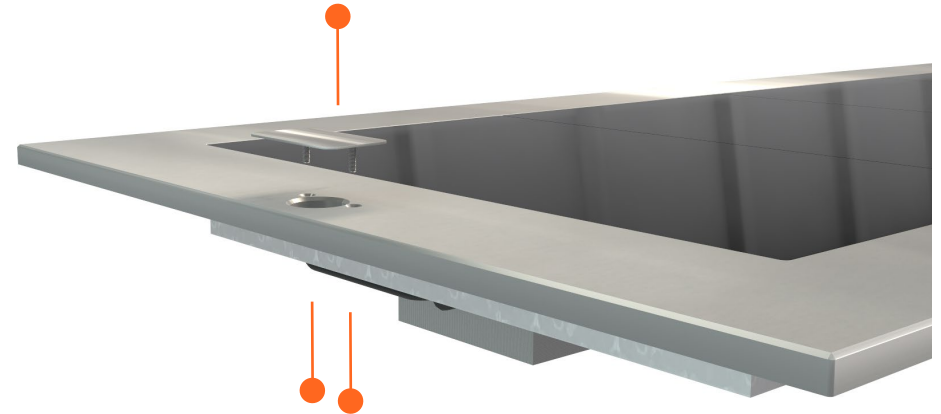
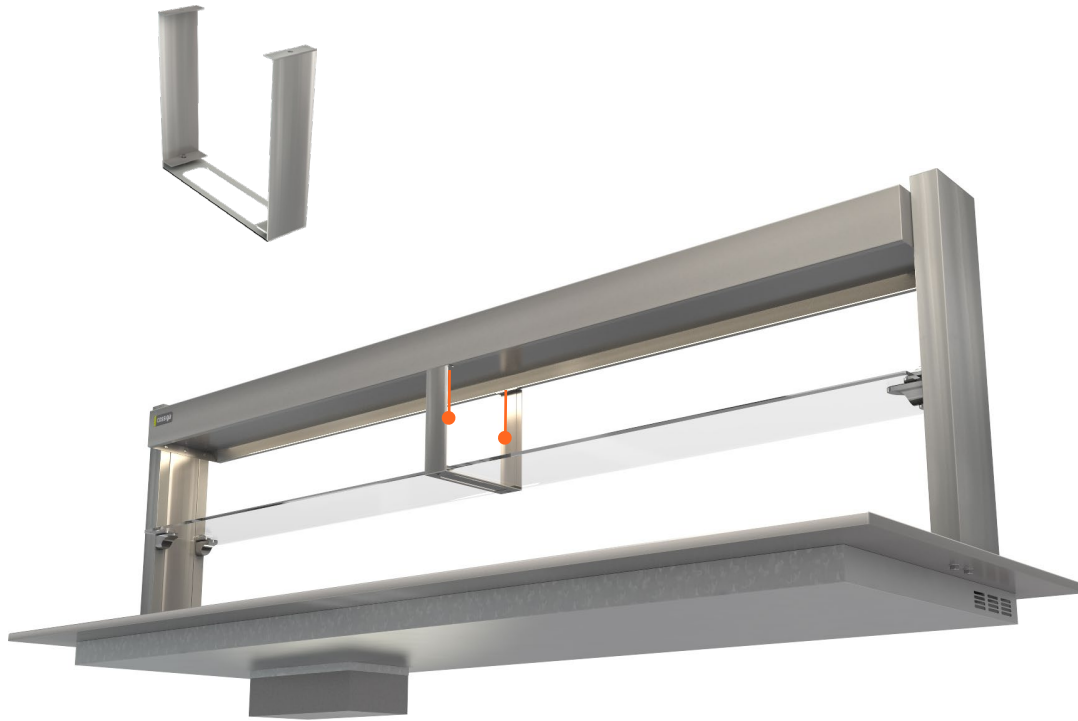

9.

NOTE: LS5 -LS6 units come with a two piece glass mid shelf and bracket. The bracket is screw fixed to the middle underside of the lamp box

10.

If the gantry is not to be used a blanking plate is supplied. Insert into position each side and fix with a bead of food grade silicone

Please Note : NOT utilising the Cossiga overhead heat source on the LSBM and LSCM models could affect performance, ensure you have an alternative heat source over each gastro area at 420mm above plate height WITH A 300 WATT HEATING POWER