



PRODUCT FEATURES

- Heated double glazed glass top and sides
- Sliding doors front and rear double glazed
- Deck forced refrigeration
- Two adjustable shelves
- Ticket strips on shelves and deck
- Under shelf and canopy LED lights
- Integral condenser
- Self evaporating
- Solid glass front - optional

CABINET DIMENSIONS & SPECIFICATIONS

Refrigerated 4⁰ factory set point

Model	Cabinet			Shelving no.	Display m2	Total food units	Refrigerant	Operating Current	Connection	Voltage
	Length mm	Depth mm	Height mm							
STGRF9-SD	900	650	925	2 + base	0.96	84	R290	5.0 Amp	10amp 3 pin plug	240V

* prior to installation see, installation guidelines, ventilation requirements and drainage options documents

ELECTRICAL POWER

Electrical power cord 2200mm
3 pin 10 amp 1 phase socket required.
Maximum ambient operating temperature climate class N max 32°C

Maximum shelf load weight 15kg
spread evenly

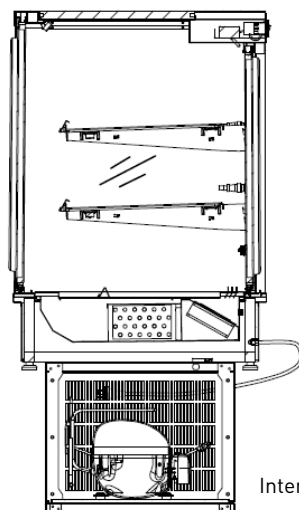
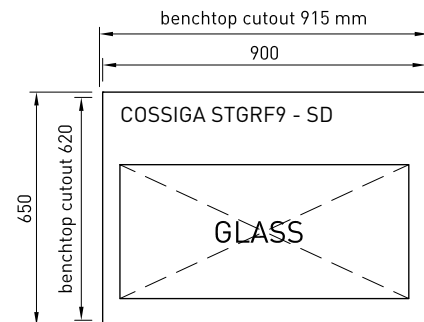

Internal condenser

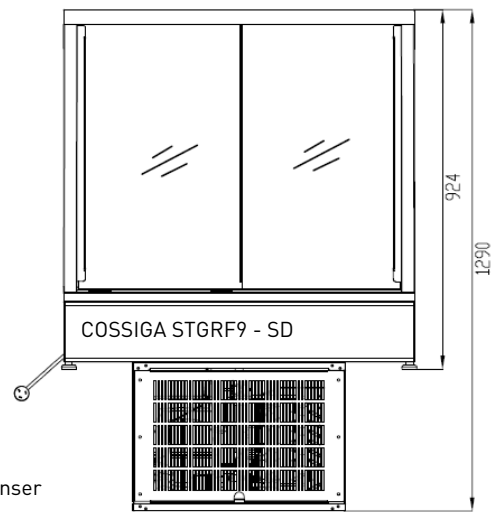

FRONT



Electrical Safety & EMC
Regulatory Compliance Mark



GEMS / MEPS Compliance Mark

[Download C.A.D models or contact us on COSSIGA.COM](#)