

3/8" pipe max run 1500 mm

Vertical pipe runs are not recommended

Pipe runs over 150mm :

Expansion valve will need to be fitted

Correctly sized condensing unit fitted

Correct pipe size determined

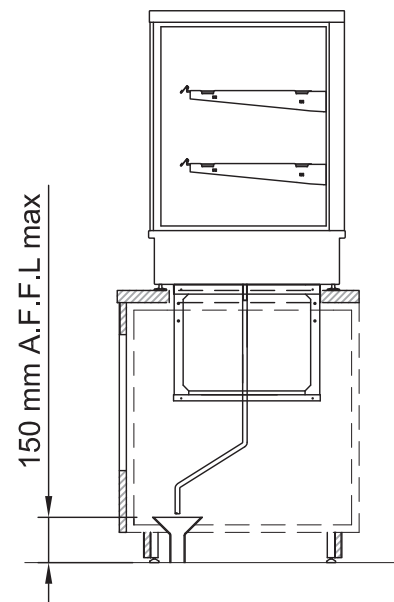

Plumbed

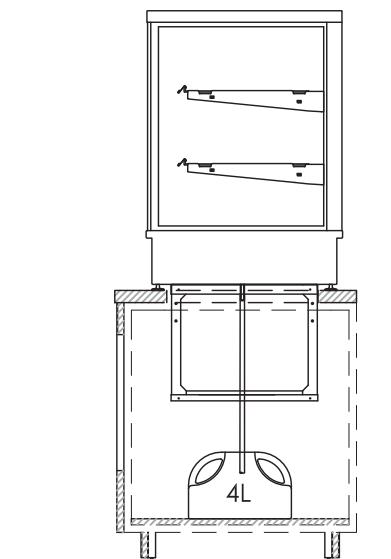

Receptacle

Units are self evaporating to a receptacle in the condensor unit  
in areas of high humidity units should be plumbed directly to a waste.

Maximum 150 mm above finished floor level

Receptacle placed under unit

Drainage to building waste

Building waste by client