

DTG OR15 OPEN FRONT MULTIDECK

COSSIGA



- Stainless steel construction
- Four adjustable shelves
- Ticket strips on shelves
- Shelf mounted air curtains
- Under shelf and canopy LED lights
- Pull down night blind
- Forced air circulation
- Integral condenser
- Removable front grille panel
- Roll in on castors
- Climate class M1
- Hinged front doors - **optional**



Shown with optional frameless hinged acrylic front doors
sold as accessory kit

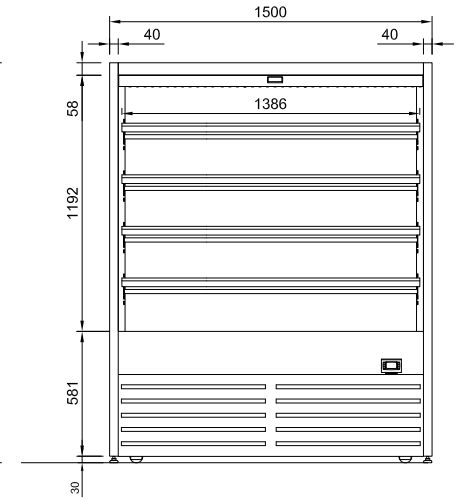
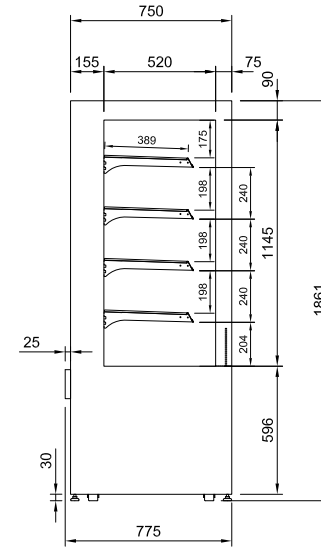
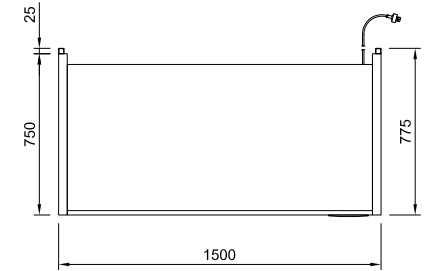
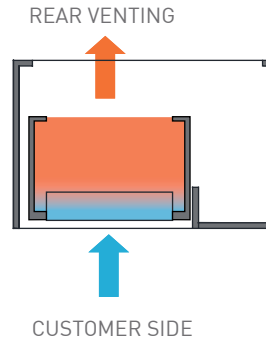

Drainage System Options

- Plastic bottle - manual empty
- Pump to waste
- Electronic evaporator pan

CABINET DIMENSIONS & SPECIFICATIONS

Prior to installation see, installation guidelines, ventilation requirements and drainage options documents

MODEL	CABINET				SHELVING	OPERATING TEMP	SHELF	BASE TRAY	DISPLAY	REFRIGERANT	FREQUENCY	OPERATING CURRENT	POWER	CONNECTION ELECTRICAL POWER CORD 2200MM		VOLTAGE	PACKED FOR SHIPPING			
	LENGTH [MM]	DEPTH [MM]	HEIGHT [MM]	WEIGHT [KG]										DEG C	W X D		W X D	M ²	TEMP CLASS M1	Hz
DTGOR15	1500	775	1860	298	4 + BASE	-1 +5	1386 X 386	1420 x 453	2.78	R290	50/60 HZ	11	15.3	3 PIN PLUG	3 PIN PLUG	220-240V	1600	830	2030	298

Maximum shelf load weight 15kg spread evenly