



PRODUCT FEATURES

- All glass Heated - fully tropicalized cabinet
- Double glazed, condensation free, glass on glass construction
- Sliding double glazed rear doors argon filled
- Deck forced refrigeration
- Double glazed with painted edges
- Adjustable shelf
- Ticket strips on shelf and deck
- Under shelf and canopy LED lights
- Integral condenser, self evaporating
- Second shelf optional

CABINET DIMENSIONS & SPECIFICATIONS

Refrigerated 4⁰ factory set point

Model	Cabinet			Shelving no.	Display m2	Total food units	Refrigerant	Operating Current	Connection	Voltage
	Length mm	Depth mm	Height mm							
						100 x 100 mm				50/60 Hertz
GOGRF9	900	650	698	1 + base	.72	72	134a	4.6 Amp	10amp 3 pin plug	240V

* prior to installation see, installation guidelines and ventilation requirements documents

ELECTRICAL POWER

Electrical power cord 2200mm
3 pin 10 amp 1 phase socket required.
Maximum ambient operating temperature climate class N max 32°C

Maximum shelf load weight 15kg
spread evenly

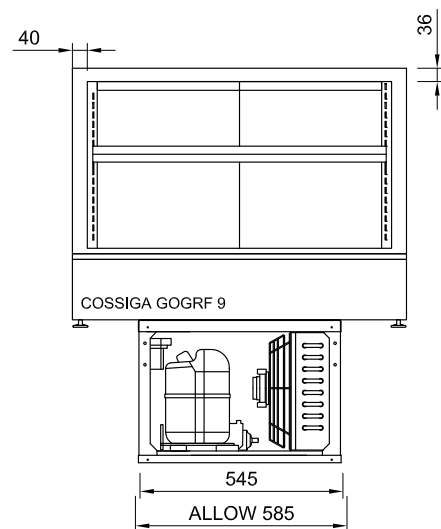
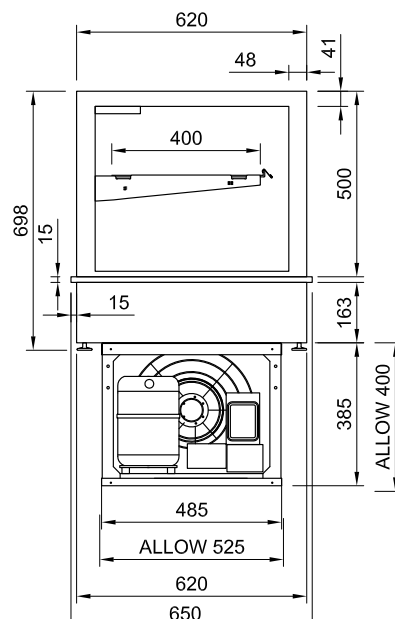
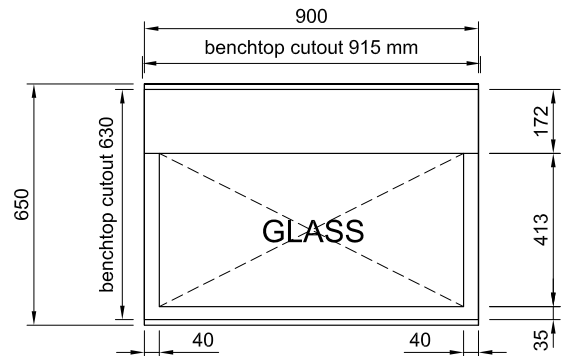



PRODUCT FEATURES

- All glass Heated - fully tropicalized cabinet
- Double glazed, condensation free, glass on glass construction
- Sliding double glazed rear doors argon filled
- Deck forced refrigeration
- Double glazed with painted edges
- Adjustable shelf
- Ticket strips on shelf and deck
- Under shelf and canopy LED lights
- Integral condenser, self evaporating
- Second shelf optional

CABINET DIMENSIONS & SPECIFICATIONS

Refrigerated 4⁰ factory set point

Model	Cabinet			Shelving no.	Display m ²	Total food units	Refrigerant	Operating Current	Connection	Voltage
	Length mm	Depth mm	Height mm							
GOGRF12	1200	650	698	1 + base	1.0	99	134a	5.4 Amp	10amp 3 pin plug	50/60 Hertz

* prior to installation see, installation guidelines and ventilation requirements documents

ELECTRICAL POWER

Electrical power cord 2200mm
3 pin 10 amp 1 phase socket required.
Maximum ambient operating temperature climate class N max 32°C

Maximum shelf load weight 15kg
spread evenly

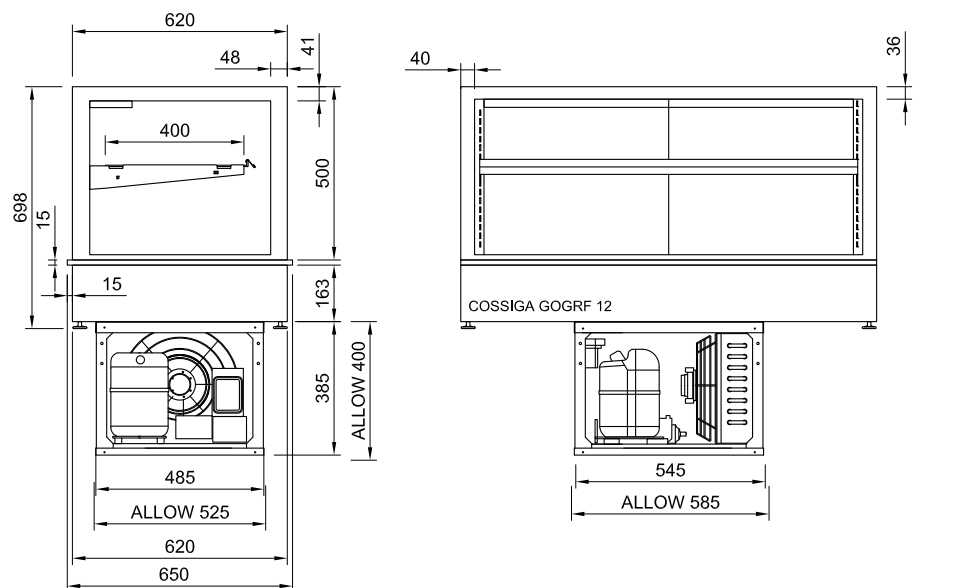



PRODUCT FEATURES

- All glass Heated - fully tropicalized cabinet
- Double glazed, condensation free, glass on glass construction
- Sliding double glazed rear doors argon filled
- Deck forced refrigeration
- Double glazed with painted edges
- Adjustable shelf
- Ticket strips on shelf and deck
- Under shelf and canopy LED lights
- Integral condenser, self evaporating
- Second shelf optional

CABINET DIMENSIONS & SPECIFICATIONS

Refrigerated 4⁰ factory set point

Model	Cabinet			Shelving no.	Display m2	Total food units	Refrigerant	Operating Current	Connection	Voltage
	Length mm	Depth mm	Height mm							
GOGRF15	1500	650	698	1 + base	1.26	126	134a	6.0 Amp	10amp 3 pin plug	50/60 Hertz

* prior to installation see, installation guidelines and ventilation requirements documents

ELECTRICAL POWER

Electrical power cord 2200mm
3 pin 10 amp 1 phase socket required.
Maximum ambient operating temperature climate class N max 32°C

Maximum shelf load weight 15kg
spread evenly

